

Swann Technical Support

All Countries E-mail: tech@swann.com.au

Telephone Helpdesk

UNITED STATES toll free
1-800-627-2799
1-877-274-3695
(Su, 2pm-10pm US PT)
(M-Th, 6am-10pm US PT)
(F 6am-2pm US PT)
USA Exchange & Repairs
562-777-2551
(M-F, 9am-5pm US PT)

AUSTRALIA toll free
1300 138 324
(M 9am-5pm AUS ET)
(Tu-F 1am-5pm AUS ET)
(Sa 1am-9am AUS ET)
New Zealand toll free
0800 479 266
International
+61 3 8412 4610

See <http://www.worldtimeserver.com> for information on different time zones and the time in Melbourne Australia compare to your local time.

WARNING: IMPORTANT NOTICE ABOUT CORRECT USE OF POWER ADAPTER

The correct orientation for the enclosed power adapter is in a vertical or floor mount position.

L'orientation correcte pour L'adaptateur secteur fourni est dans une position verticale ou plancher-monte.

La orientacion correcta para el adaptador electrico incluido es en posicion vertical o instalado en el suelo.



Warranty Information

Swann Communications U.S.A. Inc.
12636 Clark Street
Santa Fe Springs, CA 90670 USA
1-800-627-2799

Swann Communications PTY. LTD.
Building 4, 650 Church Street,
Richmond, Victoria 3121 Australia
1300 138 324

Swann Communications warrants this product against defects in workmanship and material for a period of one (1) year from it's original purchase date. You must present your receipt as proof of date of purchase for warranty validation. Any unit which proves defective during the stated period will be repaired without charge for parts or labour or replaced at the sole discretion of Swann. The repair or replacement will be warranted for either ninety days or the remainder of the original one year warranty period, whichever is longer. The end user is responsible for all freight charges incurred to send the product to Swann's repair centres. The end user is responsible for all shipping costs incurred when shipping from and to any country other than the country of origin. The warranty does not cover any incidental, accidental or consequential damages arising from the use of or the inability to use this product. Any costs associated with the fitting or removal of this product by a tradesman or other person or any other costs associated with its use are the responsibility of the end user. This warranty applies to the original purchaser of the product only and is not transferrable to any third party. Unauthorised end user or third party modifications to any component or evidence of misuse or abuse of the device will render all warranties void.



www.swannsecurity.com



ADW-300/X

Extra Digital Wireless Camera
Wireless Outdoor Camera

English



Swann Help Desk
Has the answers



If this device does not work when you first plug it in, do not take it back to the store.

- ✓ Contact the Swann Helpdesk using our fast e-mail service **tech@swannsecurity.com** or call us on one of the Toll-Free numbers shown on the back cover of this booklet.
- ✓ Most problems can be quickly and easily fixed with a simple e-mail or a quick chat with one of our friendly technical staff. (Toll-Free available in the US and Australia only)

Note: Wireless Networks (WiFi) may interfere with and/or experience interference caused by the transmitter in this unit. Changing the receiver to another channel/frequency or setting the Wireless Network (i.e. Wireless Access Point) to a frequency further away from the camera's set frequency can alleviate this problem. Consult the documentation of your Wireless LAN device for information on how to change the transmission frequency.

Installation Guide

Index

Introduction	2
Package Contents	2
Important Safety Instructions	3
Camera & Receiver Layout	4
Installation	4
Pairing Cameras	5
Troubleshooting, Hints & Tips	6
Technical Specifications	7
Help Desk / Support Details	Back Cover
Warranty Information	Back Cover

Introduction

Thank you for purchasing the Extra ADW-300 Digital Wireless Camera by Swann. The ADW-300 represents a leap forward in Wireless Security with improved reception and reliable transmission of digital signals. Please read this user manual carefully before installing or using these units.

Important Safety Precautions: Please read before installing and using this product. Damages caused by non-compliance with this operating manual will void the warranty. We will not assume any liability for damages to items or persons caused by improper handling or non-compliance with the safety notices. Any warranty claim will be null and void in such cases.

Package Contents

- 1 x Wireless Camera
- 1 x Camera Stand
- 1 x AC/DC Adaptor for Camera
- 1 x Antenna
- Quick Start Guide & Accessories

If any of these items are missing, please contact your Swann for assistance.

NOTE:

All jurisdictions have specific laws and regulations relating to the use of cameras. Before using any camera for any purpose, it is the buyer's responsibility to be aware of all applicable laws and regulations that prohibit or limit the use of cameras and to comply with the applicable laws and regulations.

The legality of watching people other than yourself changes from country to country and even state to state. Contact your local government's privacy information body or your local Police for more information on what if any restrictions you may face.

Troubleshooting (cont)

This section offers some helpful information to overcome most of the problems you may encounter.

About 2.4GHz Digital Wireless Signal: This innovative digital wireless solution integrates advance Frequency Hopping Spread Spectrum (FHSS) technology. This technology greatly reduces the interference that comes from other devices using the same radio frequency (2.4GHz), e.g. WIFI, Bluetooth, Zigbee, cordless phone etc. You now can enjoy a more pleasant wireless surveillance quality without flicking and noisy image. However, weaker signal (lag or still image) can be observed yet from time to time, depending on the environment where the system is installed. Complied with FCC part 15.247, ETSI (EN) 300 328, audio / video signals transmitted out about or over 500 ft / 150 m in line of sight should be supported. Line of sight installation, though, is usually not a common practice. Factors affecting transmission include microwave ovens or other high frequency electromagnetic waves. Reinforced concrete walls, large scale metal products and metal furniture should not be located near the camera or the receiver. Obstacles as a person passing through may cause an unstable signal.

How do I improve the wireless signal quality? If possible, remove obstacles in between camera and receiver that might deflect the signal. These could include furniture, cabinets, and walls. If you feel the wireless signal is not good enough, place the receiver at a new angle or readjust its position to make an improvement. Or simply relocate the camera closer to the receiver.

How to improve the image quality? On QVGA size (X2, zoom IN), pixel scattering is unavoidable. However, you can try to zoom out the image to VGA size. By doing so, more pixels can be scattered on the monitor or have the best display performance, 32 inch or smaller monitor / TV is suggested.

Technical Specifications

Image

Image Sensor	1/4" CMOS Sensor
Video Quality	380 TV Lines
No. of Effective Pixels	640 x 480 (VGA) / 320 x 240 (QVGA)
Minimum Illumination	2 Lux Color, 0 Lux B&W
Day/Night Mode	Automatic
Lens	F3.6mm
Viewing Angle	H:53°,V:40°

Night Vision

Number of Infra-Red LEDs	24
Infra-Red Wavelength	850nm
Night Vision Distance	25' (8m)

General

Power Supply	DC 5V
Operating Temperature	14°F to 122°F, 10°C +50°C
Dimensions - Camera	6.3" x 2.5" x 6.3", 160x63x161mm
Weight	0.7lbs, 320g
PC Out	USB Compatible
TV Out	3.5mm jack to RCA

Wireless

Reception Range	165', 50m
Frequency	2.4GHz
Transmission Channels	Frequency Hopping GFSK

Troubleshooting, Hints & Tips

Before requesting service, please make the below checks. If you are in doubt about some of the check points, or if the remedies indicated in the chart do not solve the problem, please contact us.

Problem	Possible Causes	Remedies
System message shows "NO Connection"	No power supply to corresponding camera(s)	First identify the channel number, find the corresponding camera. If camera power status indicator (RED LED) is off, check power adapter and power cable connection.
	Channel is not paired with camera yet	First identify camera has no image, draw the camera near the receiver then pair the camera to desired channel. See page 5 for detail. Once pairing completed and camera is picked up by the receiver, camera status indicator (GREEN LED) will light up.
	Service out of range	Draw the camera near the receiver
	Signal been blocked	If possible, remove major obstacles between the camera and the receiver. Or relocate the camera to proper location.
	Camera antenna connection loss	Secure camera antenna to camera body tightly.
Low signal or unstable signal	Antenna directional limitation	Adjust camera antenna and receiver position.
	Signal being blocked	If possible, remove major obstacles between camera and receiver. Or relocate the camera to proper location.
	Strong radio signal near by	Keep WIFI router away from the camera and/or receiver.
	Strong electromagnetic interference nearby	Keep working motors (hair dryer/heat fan/air conditioner/water pump) or microwave oven away from the camera and/or receiver.
Channel(s) disappear during auto or manual scan	Scan channel(s) been set OFF	Go to the receiver menu and enable the correct channel(s). See receiver instructions for details.
Dim/over-bright image at night time	Low light vision distance too short/too far	Ideal low light vision distance is from 9ft / 3m to 25ft / 8m. Adjust the camera to have camera view fit in this distance.

Important Safety Precautions

Please read before installing and using this Product. Damage caused by non-compliance with this operating manual will void the warranty. We will not assume any liability for damages to items or persons caused by improper handling or non-compliance with the safety notices. Any warranty claim will be null and void in such cases.

- Do not drop, puncture or disassemble the camera or receiver; otherwise the warranty will be voided.
- Keep adapters away from moisture.
- Never tug on the power cords. Use the plug to unplug it from the wall outlet.
- Do not expose the camera or receiver to extreme high temperatures or aim the lens in direct sunlight. Doing so may damage the camera.
- Use the devices with care. Avoid pressing hard on the camera or receiver body.
- For your own safety, avoid using the camera or power off the camera when there is a storm or lightning.
- Remove the power adapter during long periods between usages.
- Use only the accessories and power adapters supplied by the manufacturer.
- To meet the regulations pertaining to parental responsibility, keep the devices out of the reach of infants.
- Check power cables do not get crushed or damaged by sharp edges whenever the devices are in operation.



FCC Compliance Statement:
This device complies with Part 15 of the FCC Rules. Operation is subjected to the following two conditions:
(1) this device may not cause harmful interference, and
(2) this device must accept any interference received, including interference that may cause undesired operation.



**Products with CE Marking comply with EMC Directive (2004/108/EC); Low Voltage Directive (73/23/EEC); R&TTE(1999/5/EC) issued by the Commission of the European Community. Compliance with these directives implies conformity to the following European Norms:
EMC: EN 301 489
LVD: EN 60950
Radio: EN 300 328**

FCC/CE WARNING

This equipment has been tested and found to comply with limits for a Class B digital device, pursuant to Part 15 of the FCC rules and ETSI (EN) 300 328. These limits are designed to provide reasonable protection against harmful interference in residential installations. This equipment generates, uses, and can radiate radio frequency energy, and if not installed and used in accordance with the instructions, may cause harmful interference to radio communications.

However, there is no guarantee that interference will not occur in a particular installation. If this equipment does cause interference to radio or television equipment reception, which can be determined by turning the equipment off and on, the user is encouraged to try to correct the interference by one or more of the following measures:

- Reorient or relocate the receiving antenna.
- Move the equipment away from the receiver.
- Plug the equipment into an outlet on a circuit different from that to which the receiver is connected.
- Consult the dealer or an experienced radio/television technician for additional suggestions.

You are cautioned that any change or modifications to the equipment not expressly approved by the party responsible for compliance could void Your authority to operate such equipment.

Disposal

If the camera system no longer functions or can no longer be repaired, it must be disposed of according to the valid statutory regulations. Disposal of spent batteries / accumulators:



You are required by law (Battery Ordinance) to return all spent batteries and accumulators. Disposing of spent batteries/accumulators with common household waste is prohibited! Batteries/accumulators that contain hazardous substances are marked with the symbols on the side. These symbols indicate that it is prohibited to dispose of these batteries/accumulators in the household waste.

The abbreviations for the respective heavy metals are: Cd= cadmium, Hg= mercury, Pb= lead. You can return spent batteries and accumulators that can no longer be charged to the designated collection points in your community, outlets or wherever batteries or accumulators are sold. Following these instructions will allow you to fulfil the legal requirements and contribute to the protection of our environment!

Camera & Receiver Layout

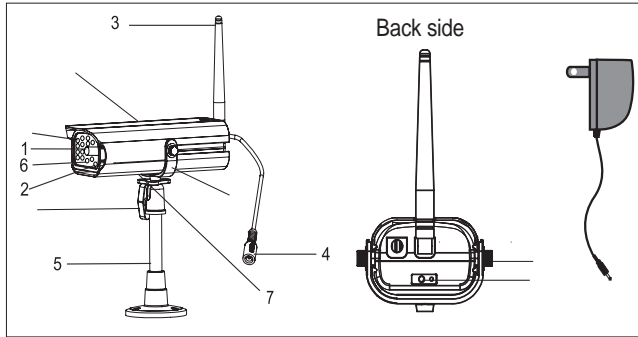

Camera Parts

1. Camera Lens
2. IR LED
3. Antenna
4. Power Jack
5. Camera Stand
6. 1 CDS
7. Microphone
8. Cam Pair
9. Power adaptor
10. Power LED
11. U holder / U holder screw
12. T- bolt
13. Sunshield

Installation

Hardware Set Up

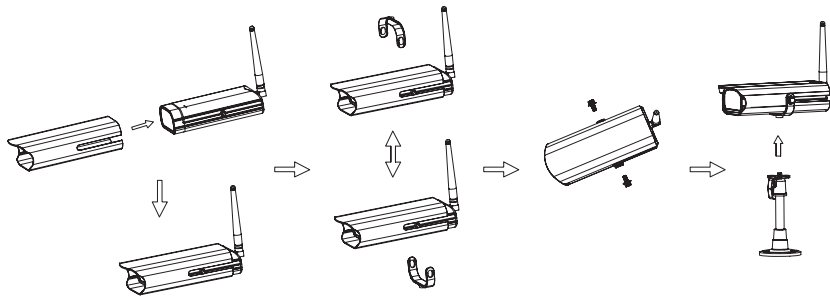

Camera Assembly / Adjustment

- A. Loosen U holder screws; slide the sunshield to ideal position.
- B. U bracket can be installed on camera top side for ceiling mount.
- C. Secure U holder with screws when done.
- D. Adjust camera for proper view angle. Secure the stand with T-bolt when done.

Camera Wall / Ceiling Mounting

- A. Secure camera stand to the wall
- B. Secure camera U bracket to the stand.
- C. Adjust proper view angle then secure the joint with T-bolt.

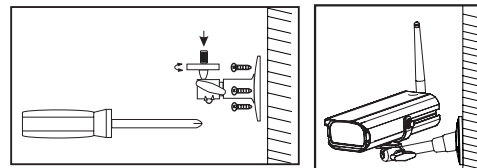

Connect Antenna & Power Adapter

- A. Secure Antenna to the camera
- B. Connect the Power Adapter included in this pack to the camera
- C. Plug in Power Adapter to power point

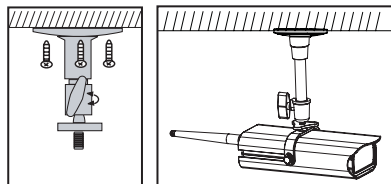

Pairing Cameras

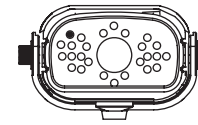

Pairing Camera(s)

- ⚠ This function is available for multi-camera users
- ⚠ It is highly recommended to pair the camera before hardware installation.
- ⚠ Before pairing the camera, make sure camera is power ON, camera status indicators shown:

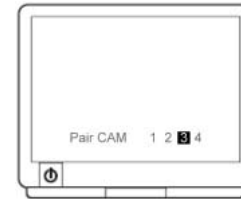

- A. Simply pair the camera by selecting the desired channel in the OSD menu of the existing receiver (not included).
- B. Only assign one camera to one channel. Channel memory will be overwritten if the next camera is assigned to the same channel.
- C. Pairing new camera to channel 3, settings as shown:

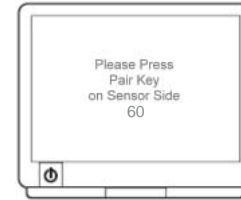

- D. Press (Pair).
- E. System will count down within 60 seconds, system message as shown:

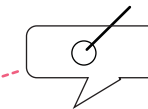
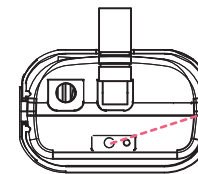

- F. Within 10 seconds, press the Pair Key on the back of camera.

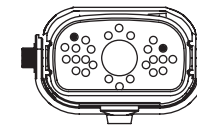
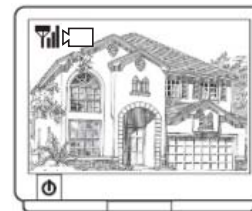

- G. Once pairing completed, camera and receiver status indicators appear as shown

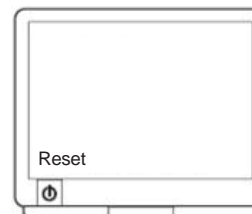

Reset

- A. Select the item "Reset" in the menu.
- B. Press .
- C. The original default settings of the system will be restored.